

Brochure of Vacuum Glass Lifter Robot

Qingdao Sinofirst Machinery Co.,Ltd Tel/Whatsapp/Wechat: +86-13668863425 Email: alison@liftawp.com



www.sagafirst.com



GL-LD Series



GL-HD Series



GL-MT Series



GL-SC Series

- ✓ **GL-LD series** can reach a height of 3.7m, even can be customized to 5m. Its boom arm is very flexible with 360° rotation and 180° tilt frame pad. So it's widely used for handle, moving and installing glass, windows, doors and other heavy panels etc. Load capacity: 300kg, 400kg, 500kg, 600kg, 800kg.
- ✓ **GL-HD series** is gantry mounting and floor crane chassis. The 2pcs of front supporting legs can be customized to balance wheel, work with CNC machine. Its max lifting height is 1.6m with 90° vertical up/down pad frame. Lifting height can be customized higher as per requests. Price is economic. Widely used to transport heavy panels, like move marbles to CNC machine for cutting. Load capacity: 400kg, 600kg, 800kg, 1000kg or more.



1

GL-LD Series

GL-LD series is **Rear Driving**, compact body, specially design for handling different kinds of heavy plate, board and glass, installing steel board, glass wall, granite, marble etc.

Rough terrain type is a senior machine with **Front Driving**, which gave better road holding and friction force while driving with loads.



1.1 Hot Sale Vacuum Lifter Robot

Operation Video on Youtube: <https://youtu.be/ppeR2-OfZ6Y>

ModelType	GL-LD-300	GL-LD-400	GL-LD-500	GL-LD-600	GL-LD-800
LoadCapacity	300kg(retract) 150kg(extend)	400kg(retract) 200kg(extend)	500kg(retract) 250kg(extend)	600kg(retract) 300kg(extend)	800kg(retract) 400kg(extend)
LiftingHeight	3600mm	3600mm	3700mm	3700mm	5000mm
QTY of Suction Cap	4pcs	4pcs	6pcs	6pcs	8pcs
Rubber Suction Cap	300mm	Ø300mm	Ø300mm	Ø300mm	Ø300mm
Deep Cycle Battery	2x12V/80AH	2x12V/100AH	2x12V/120AH	2x12V/120AH	2x12V/120AH
Battery Charger	Smart Charger	Smart Charger	Smart Charger	Smart Charger	Smart Charger
Drive motor	24V/1200W	24V/1200W	24V/1200W	24V/1200W	24V/1500W
Lifting Motor	24V/2000W/10L	24V/2000W/10L	24V/2000W/10L	24V/2000W/10L	24V/2200W/12L
Chassis L*W	2660*810mm	2660*810mm	2800*810mm	2800*810mm	2800*810mm
Driving Wheel	Ø250x80mm	Ø250x80mm	Ø300x100mm	Ø300x100mm	Ø300x125mm
Packing Size(mm)	2560*1030*1700	2560*1030*1700	2580*1050*1700	2580*1050*1700	3000*1250*2300
N.W/G.W	1100/1150kg	1280/1330kg	1300/1350kg	1400/1450kg	1600/1650kg
Loading Qty	1x20GP/40GP: 6SETS/12SETS				
Movements	Automatic (4 kinds)	Pad frame vertical up/down 180° automatic, Boom in/out TELESCOPIC automatic, Powered arm up/down automatic, Lateral side shift 100mm automatic			
	Manual (2kinds)	Pad frame tilt 180° manual, Pad frame rotation 360° manual (optional automatic moving being showed on following page)			
Usages	Mainly used for handling, moving and installing glass, marble, wooden panel etc.				

Options and Movements GL-LD Series

Standard configurations:

4 kinds of Automatic movement(in blue)

2 kinds of manual movement(in red)

Options as below:

Optional 1> Need pad frame automatic rotation 360°
Optional 2> Need pad frame automatic tilt
Optional 3> Need remote control
Optional 4> For curved glass,need to customize the pad frame
Optional 5> For rude surface panels,need to use sponge suction cup and bigger system
Optional 6> Customized painting color:FREE

- 1) Anticlockwise rotation - 逆时针旋转
- 2) Side turning (to the right) - 侧转 (向左)
- 3) clockwise rotation - 顺时针旋转
- 4) Side turning (to the left) - 侧转 (向右)
- 5) Suction - 吸气
- 6) Air release - 放气
- 7) Start the remote control - 启动遥控
- 8) on/off 遥控开关

- a) Side shift (to the left) - 侧移 (向左)
- b) Vacuum frame tilt up - 吸盘架上翻
- c) Side shift (to the right) - 侧移 (向右)
- d) Vacuum frame tilt down - 吸盘架下翻
- e) Boom forward - 吊臂前伸
- f) Boom up - 吊臂上升
- g) Boom back - 吊臂后收
- h) Boom down - 吊臂下降



Movements Display



Bulk In Stock



Features & Advantages:

A. Dual Vacuum System. One for normal operation and one as spare system.

B. USA Curtis control system, DC24V reliable actuators for lifting, extension and tipping. efficient and precise.

C. Japan Panasonic and Taiwan Airtac Self-contained air system, and no external air source is required.

D. USA THOMAS vacuum pump, heavy duty driving wheel, hydraulic pump, as well as maintenance-free battery.

E. Integrated with pressure auto maintaining system, even if power fails, pressure remains.

F. Independent Air Inlets. Each suction cup can be disabled individually if not all are needed.



Technical Drawing (GL-LD-300, GL-LD-400)

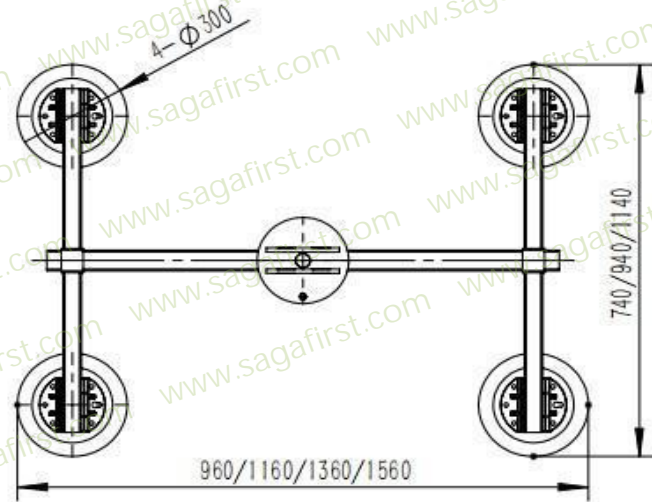
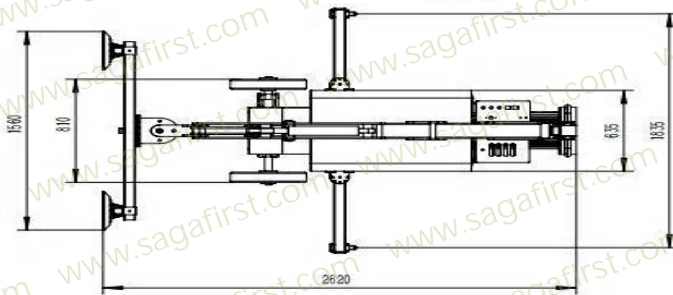
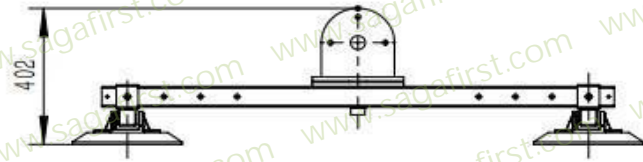
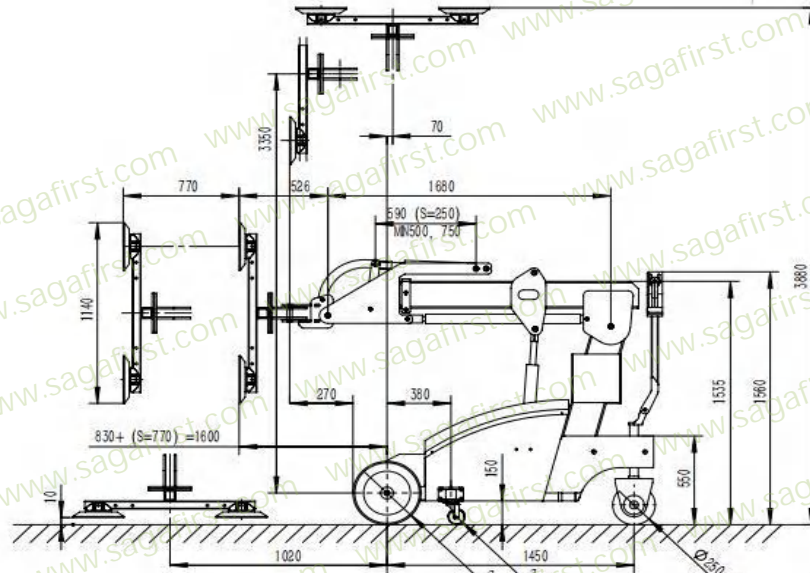

Technical Drawing (GL-LD-500, GL-LD-600)

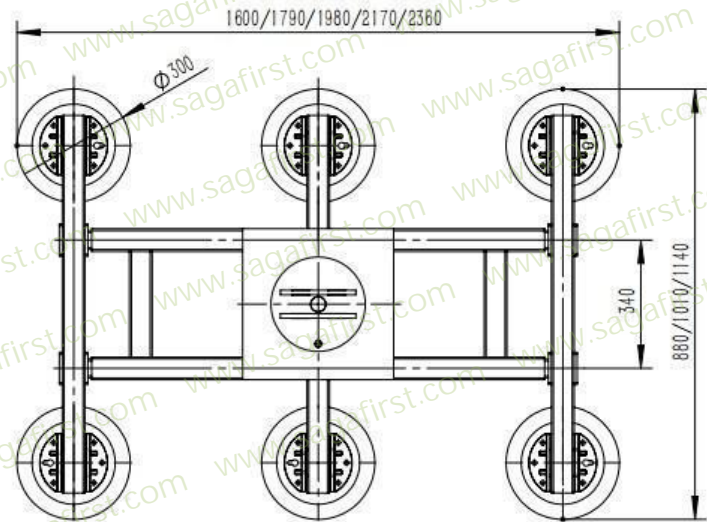
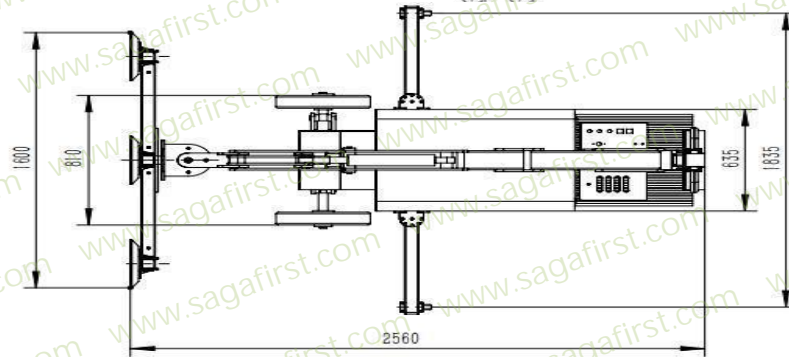
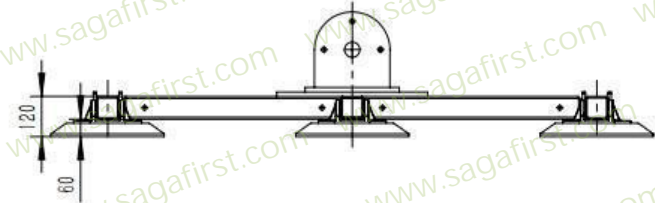
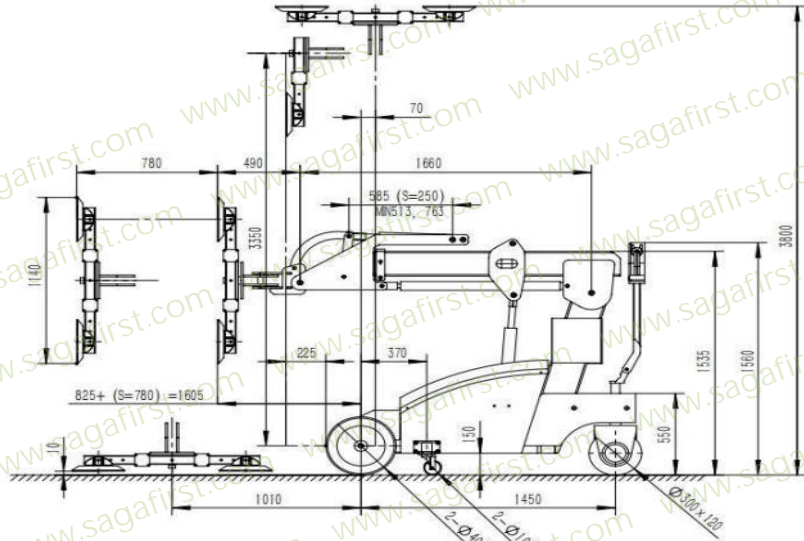

Technical Drawing (GL-LD-800)

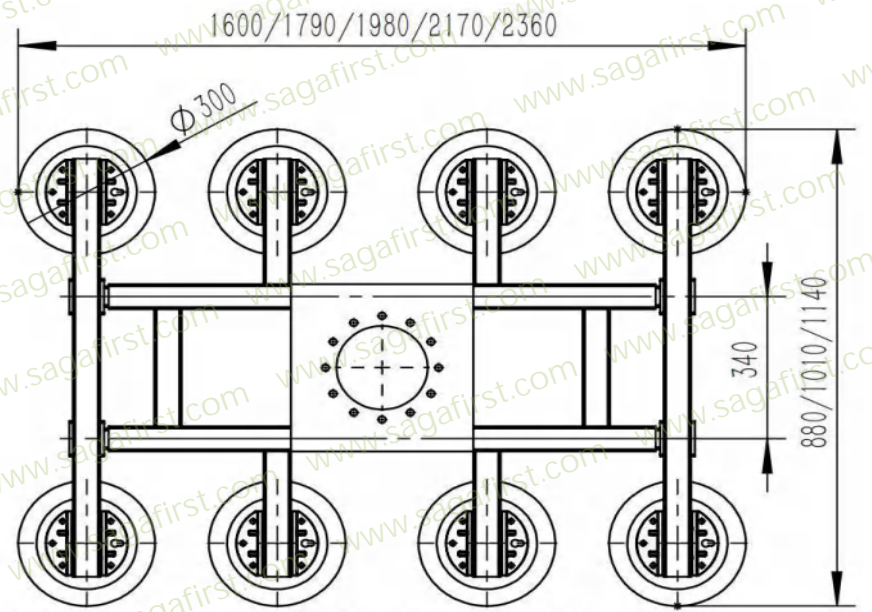
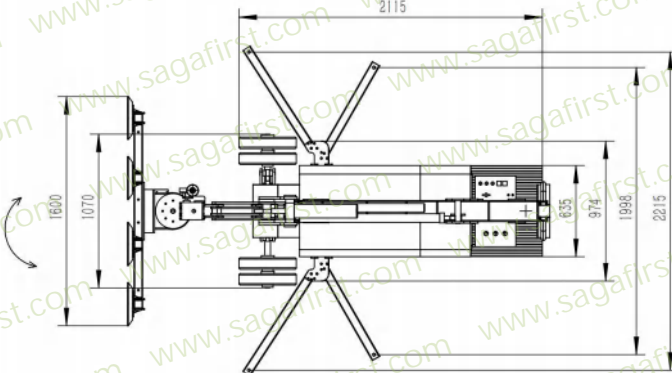
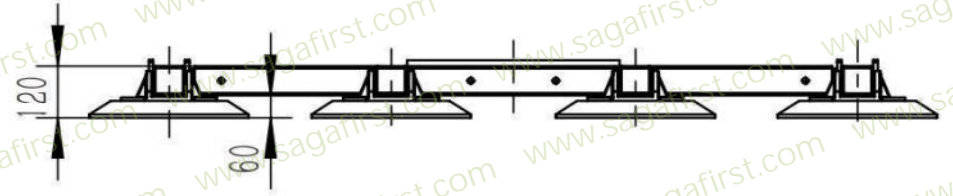
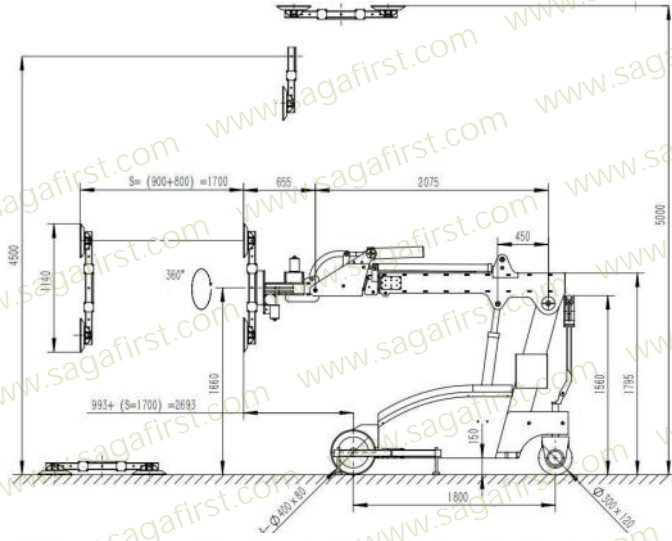

Safety Precautions

1. Anti-explosion valve: protect hydraulic pipe, anti-hydraulic pipe rupture.
2. Overflow valve: It can prevent high pressure when the machine moves up. Adjust the pressure.
3. Check valve: prevent hydraulic oil backflow
4. Emergency decline valve: it can go down when you meet an emergency or the power off.
5. Dual circuit vacuum system
6. Emergency stop button
7. Two Support Legs

Customize for different materials rude surface

Rubber sucker: round $\varnothing 300\text{mm}$
(for glass and smooth marbles)



Sponge sucker: square
400*250mm (for rude surface)



Pneumatic Schematic

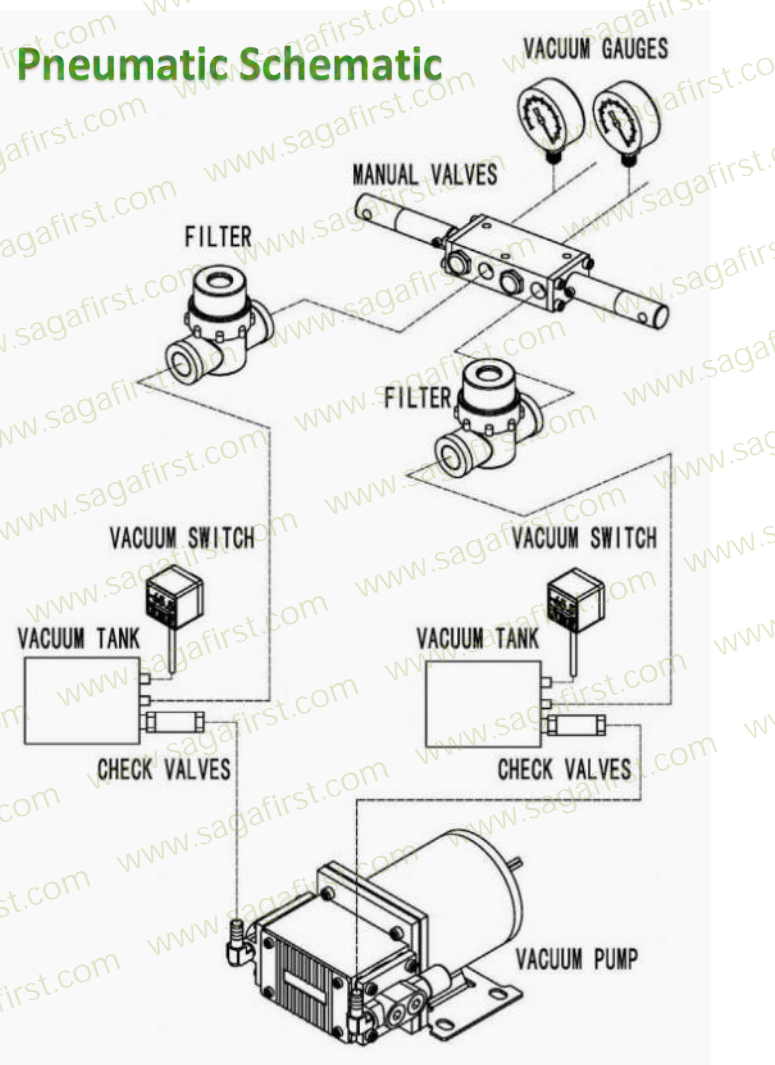

Project Cases



1.2 200kg Small Vacuum Lifter Robot

Operation Video on Youtube: <https://youtube.com/shorts/gfoQh9SIPQ4>

Model Type		GL-LD-200
Load Capacity	200kg(retract)100kg(extend)	
Lifting Height	2700mm	
QTY of Suction Cap	4pcs	
Rubber Suction Cap	250mm	
Battery	2x12V/35AH	
Battery Charger	Smart Charger	
Drive motor	24V/750W	
Lifting Motor	24V/1500W/6L	
Chassis L*W	2350*620mm	
Driving Wheel	Ø210x70mm	
Packing Size(mm)	2350*620*1700	
N.W/G.W	600/700kg	
Loading Qty	1x20/40GP: 10/20SETS	
Movement	Automatic(4 kinds)	Pad frame vertical up/down 180° automatic, Boom in/out TELESCOPIC automatic, Powered arm up/down automatic, Lateral side shift 100mm automatic
	Manual (2kinds)	Pad frame tilt left/right 90° manual (Optional, automatic) Pad frame rotation 360° manual (Optional, automatic)

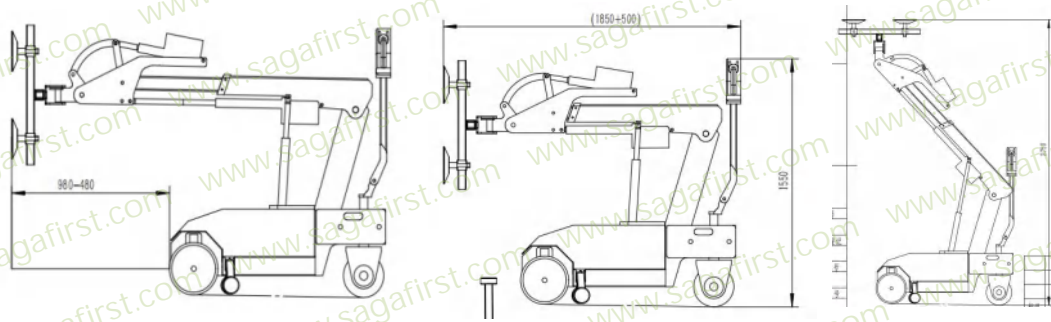

1.3 All rough terrain Vacuum Lifter Robot

Operation Video on Youtube: <https://youtu.be/klqclTPg5s4>

ModelType	GL-LD-600A	GL-LD-800A
Load Capacity	600kg (retract),300kg(extend)	800kg (retract),400kg(extend)
Lifting Height	3700mm	5000mm
QTY of Suction Cap	6pcs	8pcs
Rubber Suction Cap	∅300mm	∅300mm
Deep Cycle Battery	2x12V/150AH	2x12V/160AH
Battery Charger	Smart Charger 110v~240v	Smart Charger 110v~240v
Drive motor	3KW	3KW
Lifting Motor	24V/2KW/10L	24V/2.2W/10L
Wheel Type	Solid rubber wheel	Solid rubber wheel
Packing Size(mm)	2970*1080*1720	3200*1280*2300
N.W/G.W	1750/1850kg	1850/1950kg
Loading Qty	1x20/40GP: 6/12SETS	
Movements (On Page 3)	Automatic (4 kinds)	Pad frame vertical up/down 180° automatic Boom in/out TELESCOPIC automatic Powered arm up/down automatic Lateral side shift 100mm automatic
	Manual (2kinds)	Pad frame rotation 360° manual (Pls look at Optional 1. automatic rotation 360°) Pad frame tilt left/right 90° manual (Optional 2. automatic tilt lift/right)
Usages	Mainly used for handling, moving and installing glass, marble, wooden panel etc.	

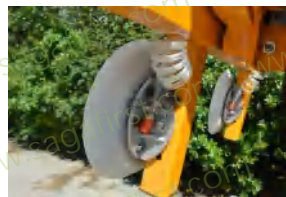

1.3 All rough terrain Vacuum Lifter Robot



1.3 All rough terrain Vacuum Lifter Robot





2

GL-HD Series





Operation Video on Youtube:
<https://youtu.be/lFIlFmaHH7A>



Specification Details

Model	GL-HD-4016	GL-HD-6016	GL-HD-8016	GL-HD-10016
Rated Load Capacity	400kgs	600kgs	800kgs	1000kgs
Safe Load Capacity	200kgs	300kgs	400kgs	500kgs
Lifting Height	1600mm	1600mm	1600mm	1600mm
QTY of Suction Caps	4pcs	6pcs	8pcs	10pcs
Cap Diameter	Ø300mm	Ø300mm	Ø300mm	Ø300mm
Plate Size(customized)	2440x1830mm	2440x1830mm	2440x1830mm	2440x3660mm or bigger
Load Center	650mm	650mm	650mm	950mm
Drive Motor	24V/500W	24V/500W	24V/500W	24V/700W
Hydraulic Motor	24V/2000W	24V/2000W	24V/2000W	24V/2000W
Battery	2x12V/70Ah	2x12V/70Ah	2x12V/70Ah	2x12V/100Ah
Charger	24V/10A	24V/10A	24V/10A	24V/15A

<h2>Options</h2>	Optional 1> Need pad frame automatic rotation 360°
	Optional 2> Need remote control
	Optional 3> For rude surface panels, need to use sponge suction cup and bigger system
	Optional 4> For balanced wheel type, rather than using 2pcs of supporting legs in front (see pictures on next page)
	Optional 5> Lifting height: 1.6m or 2.5m

Pad Frame	Pick up & rotation movements	Dual Vacuum System	Hydraulic Motor	Driving Motor
				

Vacuum Lifter for Transporting Materials (standard configurations)



Optional Counter Balanced Type Chassis

※ If you have no space to put the 2pcs outriggers in front, such as using it for a CNC cutting machine. We will customize it to balance wheel type. The size of wheels are produced as per requests.



Optional **Sponge Suction Cup** for Rude Surface Panels

✘ If the surface of your panels are rude or have some air leak, you need to use sponge suction cups. The configurations, like vacuum pump, swept volume and gas tank will be enlarged.



Semi Electric Vacuum Lifter

(Glass/Marble/Metal Sheet/Wooden Panel)

Model	GL-HD-600S	GL-HD800S
Rated Load Capacity(kg)	600	800
Safe Load Capacity(kg)	300	400
Lifting Height(mm)	1600	1600
QTY of Suction Caps	4	4
Plate Size(customized)	1220x1830	1220x1830



Features & Advantages

- a. Battery powered vacuum system
- b. Structure simple and light easy to move and portable
- c. Attractive price,working environment flexible
- d. Man push moving,electric raising,taking and release



3

GL-MT Series

	Manual	Battery
Load	200kg	400kg



Manual Glass Moving Trolley



Model		GL-MT-200M
Load Capacity	kg	200
Cup Quantity	pcs	2
Single cup load capacity	kg	100
Rotation	/	360°
Self weight	kg	55
Rear wheel	mm	350*85
Packing Size	mm	0.64 CBM
Gross Weight	kg	97

Features & Advantages

- a. Convenience with no power needed
- b. Structure simple and light easy to move and partable
- c. Attractive price, working environment flexible



Semi Electric Glass Moving Trolley

Model	/	GL-MT-400SE
Load Capacity	kg	400
Cup Quantity	pcs	4
Single cup load capacity	kg	100
Rotation	/	360°
Battery	v/ah	2*12/12
Self weight	kg	165
Rear wheel	mm	350*85
Horizontal adjusting	mm	100-200
Packing Size	mm	2440*990*600
Gross Weight	kg	185



Features & Advantages

- a. Battery powered vacuum system
- b. Structure simple and light easy to move and portable
- c. Attractive price, working environment flexible



4

GL-SC Series

Operation Video on Youtube:
Video of Working/Rotation and Tilting

<https://youtu.be/JfqoGEFVJkg>



X Type Frame (for glass and marbles)

		GL-SC-400	GL-SC-600	GL-SC-800	GL-SC-1000
Lifting Capacity	kg	400	600	800	1000
Cup Qty	/	4	6	8	10
Single Cup Diameter	mm	300	300	300	300
Single Cup Lifting Capacity	kg	100	100	100	100
Rotation	/	360° manual rotate			
Tilting	/	90° manual			
Voltage	V	DC12			
Charger	V	AC220/110 custom			
Weight	kg	70	90	100	120
Sucker Frame Size	mm	850*750*300	1800*900*300	1760*1460*300	1900*1600*300
Extension Bar Length	mm	500			
Control System	/	Integrated Control Cabinet and Wired Remote Control			
Overall Size	mm	1230*910*390mm, packed by wooden box			
Gross Weight	kg	97	110	123	150



Features & Advantages:

- Sealed cover for components protection, safe and reliable. Usually cooperated with bridge crane to use in glass deep processing and handling job, or with cantilever crane to use in glass curtain wall installation job .
- Adjustable type, can be changed the position of the suction cup to absorb glass of different shapes and sizes (also can be customized according to the glass size)
- Manually rotated 360° in the vertical side, and manually rotated 90° in the horizontal side, but taking and releasing by electric
- Adopt American THOMAS vacuum pump and high quality maintenance-free battery, no need the air source or power supply during use.
- Japan Panasonic digital display vacuum pressure switch , battery fuel gauge, clearly monitor the safty use.
- With vacuum pressure auto supply system, during handling glass, ensure the whole vacuum system maintained at a relatively constant safety pressure value
- Equipped with the power-cut but pressure-keeping device and alarm device. If power failure accidently, the pressure-keeping function can extend the handling time and make the use safer.

Options:

1. automatic rotation (extra charged)
2. automatic tilt (extra charged)
3. wireless remote control (extra charged)
4. optional electric or battery power (free)
5. optional powder coating color (free)
6. customized voltage and plug (free)
7. customized pad frame as pwer requests

H Type Frame (Customized 1500kg 1800kg 2000kg capacity)

Model		GL-SC-800H	GL-SC-1000H	GL-SC-1200H	GL-SC-1400H	GL-SC-1500H
Lifting Capacity	kg	800	1000	1200	1400	1500
Cup Qty	/	8	10	12	14	16
Single Cup Size	mm	300				
Single Cup Capacity	kg	100				
Rotation	/	360° manual rotate				
Tilting	/	90° manual				
Voltage	V	DC12, give one free spare battery for replacement				
Charger	V	AC220/110				
Weight	kg	160	170	180	190	220
Packing Size	mm	2440*1060*400				
Telescopic Bar Length	mm	600				

Options:

1. automatic rotation (extra charged)
2. automatic tilt (extra charged)
3. wireless remote control (extra charged)
4. optional electric or battery power (free)
5. optional powder coating color (free)
6. customized voltage and plug (free)
7. customized pad frame as per requests

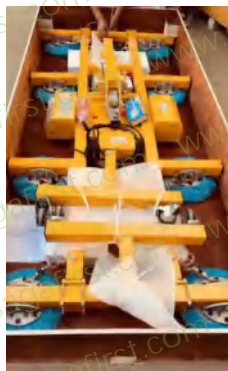



5

Line Type Vacuum Lifter

400kg capacity, with 4pcs of suction cups. It's mainly used for thin glass or other panels with narrow width.



Specification Details

		GL-SC-L400
Lifting Capacity	kg	400
QTY of Suction Cap	/	Φ300X4pcs
Rotation	/	360° manual rotate
Tilting	/	90° manual
Net Weight	kg	50
Battery	V/Ah	12/12
Charger	V/A	12/3
Power	V	110/220

Features & Advantages:

1. Sealed cover for components protection, safe and reliable. Usually cooperated with bridge crane to use in glass deep processing and handling job, or with cantilever crane to use in glass curtain wall installation job.
2. Adjustable type, can be changed the position of the suction cup to absorb glass of different shapes and sizes (also can be customized according to the glass size)
3. Manually rotated 360°, with locking facility at each 90°. and tiltable 90° manually, but taking and releasing by electric.
4. Adopt American THOMAS vacuum pump and high quality maintenance-free battery, no need the air source or power supply during use.
5. Japan Panasonic digital display vacuum pressure switch, battery fuel gauge, clearly monitor the safety use.
6. With vacuum pressure auto supply system, during handling glass, ensure the whole vacuum system maintained at a relatively constant safety pressure value
7. Equipped with the power-cut but pressure-keeping device and alarm device. If power failure accidentally, the pressure-keeping function can extend the handling time and make the use safer.
8. Equipped with 12V backup battery, can be replaced in time to ensure the progress of the project.
9. is suitable for the installation of sandwich panels up to a weight of 750 kg or a length of 12 meters. The vacuum lifter is also equipped with a single- or dual-circuit safety system, and the wireless radio remote control for optional. The battery has a charging time of about six hours, after which you can work with it all day without problems.





6

Big Suction Cup Vacuum Lifter

Big Suction caps vacuum lifter are specially design for handling different kinds of heavy plate, board and glass, useful for installing steel board, glass wall, moving such as granite, marble. It is a very compact vacuum lifter for the installation of glass and sandwich wall panels in a fast and efficient way. For fast, easy, and hassle-free installation of horizontal and vertical wall panels. This handy lifter can be used both indoors and outdoors, and is easily transported in a passenger car.

Operation Video on Youtube:
<https://youtu.be/EUi4LLA2yBQ>



Specification Details

workable for glass,marbles,metal sheet,wooden board etc.

MODEL	GL-SC-500B	GL-SC-D750B	GL-SC-D250B	GL-SC-D375B
Lifting Capacity (kg)	500	750	250	375
Net Weight (kg)	56	66	62	72
Pad Size (mm)	850*400	1000*500	800*400	1000*500
Thickness(mm)	250	250	250	250
Vacuum circuit(s)	Single-circuit	Single-circuit	Dual-circuit	Dual-circuit
Packing Size(mm)	850*450*400	1050*550*400	850*450*400	1050*550*400
Battery V/Ah	12/12	12/12	12/12	12/12
Charger V/Ah	12/3	12/3	12/3	12/3
Power V	110/220	110/220	110/220	110/220

Features & Advantages:

- Sealed cover for components protection,safe and reliable.
- Adjustable type, can be changed the position of the suction cup to absorb glass of different shapes and sizes
- Manually rotated 360°, with locking facility at each 90°.and tiltable 90°manually, but taking and releasing by electric.
- Optional automatic electric rotating ,electric tilting,remote control.
- -Adopt American THOMAS vacuum pump and high quality maintenance-free battery
- -Japan Panasonic digital display vacuum pressure switch





suitable for 3m 4m long metal sheet

7

Metal Sheet Vacuum Lifter

It's mainly used for metal sheet. Standard model type capacity is from 500kg to 2000kg. The length is from 3m to 6m.

Besides, we customize heavy duty lifters as per requests. Just tell us the weight and size of your panels.



**suitable for 6m long metal sheet
(with branch beam)**



Metal sheet Vacuum Lifter

Model Type	GL-SC-500M3	GL-SC-500M4	GL-SC-600M3	GL-SC-600M4	GL-SC-800M3	GL-SC-800M4	GL-SC-1000M3	GL-SC-1000M4	GL-SC-1000M6	GL-SC-1500M	GL-SC-2000M
Rated load capacity (kg)	500		600		800		1000		1500		2000
Suction Cup Size (mm)	φ210		φ210		φ210		φ210		φ300		φ300
Number of Cup (pcs)	6/8		6/8		8		10		8/10		10/12
Main Beam Length (mm)	2000	3000	2000	3000	2000	3000	2000	3000	2800-5000	2800-5000	2800-5000
Branch Beam Length(mm)	800	800	800	800	800	800	800	800	800	800	800
Voltage	DC12V/12Ah*2 pieces or AC 380V/50Hz										
Suitable for metal sheet Length (mm)	3000	4000	3000	4000	3000	4000	3000	4000	6000	6000	6000
Packing Size(mm)	2050*400*620	3050*400*620	2050*400*620	3050*400*620	2050*400*620	3050*400*620	2050*400*620	3050*400*620	3070*730*480	3070*730*480	3070*730*480
Weight (kgs)	140/145	150/155	145/155	155/165	155	165	160	170	235	240/255	255/275

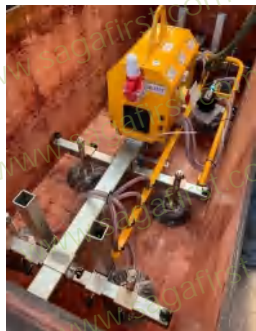

Features & Advantages:

- 1. Efficient, non-damaging handling of heavy loads
- 2. To work ergonomically and protect operator health
- 3. Excellent work safety and process reliability thanks to vacuum reservoir and audible warning device
- 4. Long service life due to a robust mixture of steel and high-strength plastic
- 5. Low operating costs thanks to controlled vacuum generator with energy saving
- 6. No longer need spaces or stoppers for storage and don't need a heavy-duty back-up power. By the aid of vacuum you never damage the load and you don't have residual magnetism.

Customized HEAVY DUTY Vacuum Lifer

(Produce as per the length and weight of your sheet)



Features & Advantages:

1. Sealed cover for components protection, safe and reliable. Usually cooperated with bridge crane to use in glass deep processing and handling job, or with cantilever crane to use in glass curtain wall installation job .
2. Adjustable type, can be changed the position of the suction cup to absorb glass of different shapes and sizes (also can be customized according to the glass size)
3. Manually rotated 360°, with locking facility at each 90°. and tiltable 90° manually, but taking and releasing by electric.
4. Germany Baker vacuum pump, Japan Panasonic vacuum sensor, Italy ITAP one-way check valve, sound and light alarm, wear resistant butyl rubber material suction cup
5. Japan Panasonic digital display vacuum pressure switch , battery fuel gauge, clearly monitor the safety use.
6. With vacuum pressure auto supply system, during handling glass, ensure the whole vacuum system maintained at a relatively constant safety pressure value
7. Equipped with the power-cut but pressure-keeping device and alarm device. If power failure accidently, the pressure-keeping function can extend the handling time and make the use safer.
8. Equipped with 12V backup battery, can be replaced in time to ensure the progress of the project.
9. Suitable for the installation of sandwich panels up to a weight of 750 kg or a length of 12 meters. The vacuum lifter is also equipped with a single- or dual-circuit safety system, and the wireless radio remote control for optional. The battery has a charging time of about six hours, after which you can work with it all day without problems.

MODEL Type	GL-SC-D5000	GL-SC-D6000	GL-SC-D8000	GL-SC-D10000	GL-SC-D12000
Capacity(kg)	5000	6000	8000	10000	12000
Pad Qty (pc)	6	6	8	10	12
Pad Size(mm)	850*450	850*450	850*450	850*450	850*450



8

Sandwich Vacuum Lifter

Sandwich roof panels can be easily installed, flat or inclined. This lifter (equipped with a single- or dual-circuit safety system) is suitable for the installation of sandwich roof panels and sandwich wall panels

Operation Video on Youtube: <https://youtu.be/204R0X8Eb54>



Specification Details <I>

GL-SC (for Roof pitch 0~25degree)



Roof Panel	Lifter Length	Panel Length	Ext Beam Qty	Max Load	Max Load on Traverse	Suction PadQty	Pad Size/Load
GL-SC-2650	2650	12000	2	300	800	8	110*530/75kg
GL-SC-4450	4450	14000	4	300	500	8	110*530/75kg
GL-SC-6250	6250	16000	6	300	300	8	110*530/75kg
GL-SC-4450L	4450	14000	4	300	800	8	110*530/75kg
GL-SC-6250L	6250	16000	6	300	500	8	110*530/75kg
GL-SC-8050L	8050	18000	8	300	500	8	110*530/75kg
GL-SC-9850L	9850	20000	10	300	500	8	110*530/75kg
GL-SC-8050LD	8050	18000	8	450	500	12	110*530/75kg
GL-SC-9850LD	9850	20000	10	450	500	12	110*530/75kg
GL-SC-1525LDD	15250	24000	16	500	500	16	110*530/75kg
GL-SC-1705LDD	17050	26000	18	500	500	16	110*530/75kg

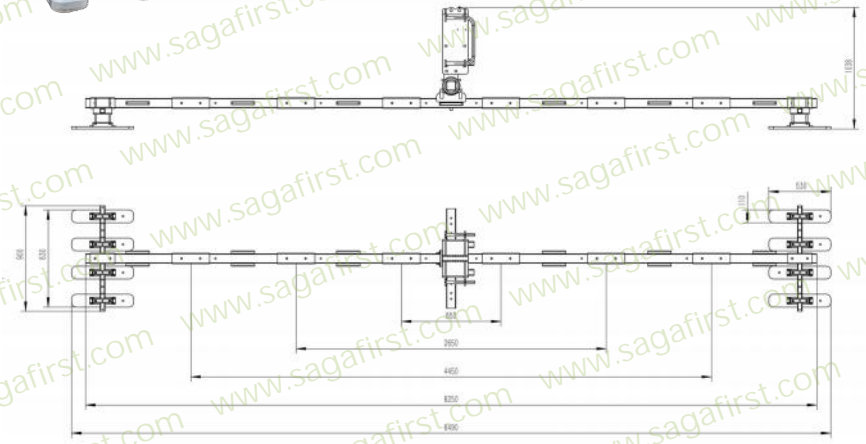

Specification Details <II>

GL-SC-T (for Roof pitch 25 ~45degree)

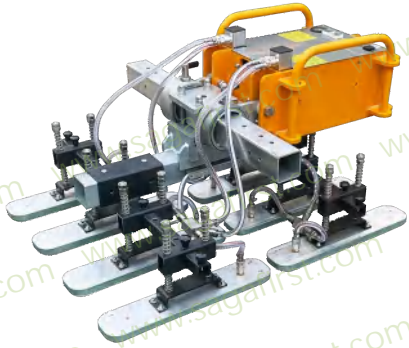

GL-SC-V

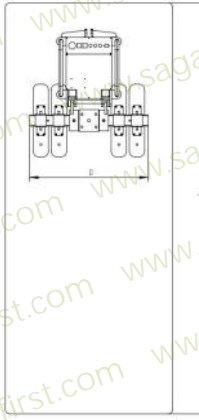

GL-SC-C

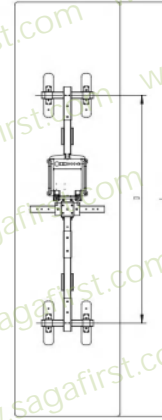

GL-SC-H

GL-SC-HL

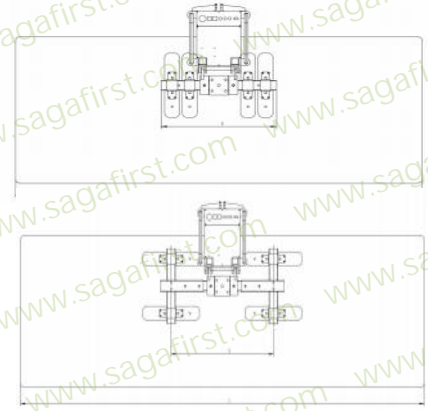

Roof Panel	Lifter Length	Panel Length	Ext Beam Qty	Max Load	Max Load on Traverse	Suction PadQty	Pad Size/Load
GL-SC-T2650	2650	12000	2	300	800	8	110*530/75kg
GL-SC-T4450	4450	14000	4	300	500	8	110*530/75kg
GL-SC-T6250	6250	16000	6	300	300	8	110*530/75kg

WallPanel	Lifter LengthD	Panel LengthL	Ext Beam Qty	Max Load	Max Load on Traverse	Suction Pad Qty	Pad Size/Load
GL-SC-V	850	12000	0	200	800	2	150*490/100kg
GL-SC-V	850	12000	0	400	800	4	150*490/100kg
GL-SC-C	2950	15000	2	400	800	4	150*490/100kg
GL-SC-C	4750	17000	4	400	500	4	150*490/100kg
GL-SC-H	850	12000	0	200	800	2	150*490/100kg
GL-SC-H	850	12000	0	400	800	4	150*490/100kg
GL-SC-HL	1150	13000	0	400	800	4	150*490/100kg
GL-SC-HL	2950	15000	2	400	800	4	150*490/100kg

Panel Size	Pad Size	Load (H)	Load (V)
3*333	110*530		
4*250	110*530		
5*200	110*530	150	75
6*116	90*550	120	60
	150*490	200	100
	70*570	80	40
customize	customize		

Placing suction pads on different panels



9

Forklift Fixture Vacuum Lifter

Operation Video on Youtube:

<https://youtu.be/Xx6u6CFmk7Q> (glass)

<https://youtu.be/peR-Y1ViJzU> (metal sheet)

Fork Mounted Vacuum Lifting Attachments - Battery self powered Vacuum lifting attachments can safely and easily be attached directly to the end of the fork, to make a practical installation device for for glass, metal, concrete slabs, plastics and laminates etc. Widely used in the factory, warehouse or on site to allow for safe and efficient glazing of glass and windows weighing up to 800kg.



Specification Details

Model Type	GL-SC-300F	GL-SC-400F	GL-SC-500F	GL-SC-600F	GL-SC-800F
Load Capacity	300kg	400kg	500kg	600kg	800kg
Suction Cup Qty	Φ250X4pcs	Φ300X4pcs	Φ300X6pcs	Φ300X6pcs	Φ300X6pcs
Battery (V/AH)	12/20 *2	12/20 *2	12/20 *2	12/20 *2	12/20 *2
Battery Charger (V/A)	24/6	24/6	24/6	24/6	24/6
Frame size	1000*800	1000*800	1350*1000	1350*1000	1350*1000
Frame extension size	1000*800	1000*800	2110*1000	2110*1000	2110*1000
Rotation Method	Manual or Powered 360°(optional)				
Side turning method	Manual or Powered 90°(Left and right)(optional)				
Packing Size(mm)	1100*800*500	1100*800*500	1240*1080*1130	1240*1080*1130	1240*1080*1130

- Battery self powered, fully integrated and independent power supply to drive the equipment
- No installation required, with 4 pcs long screw to fix the adaptor, Easily secured to forks. For added safety, securing chains supplied for optional to secure the attachment back to the forklift mast.
- Each pad can control independently, the position can be adjustable, suitable for different sizes glass
- Radio control operation for 90° tilting , release and suction
- Manual or Powered 360° rotation and Side turning/TILT for optional
- 24V charger with smart repair function
- Easy to maintain and repair on site
- Imported silicone raw material suction cup from the United States, good adsorption and anti-aging American Thomas Vacuum System design, safe and efficient
- High-power pole design, strong thrust, easy to flip
- Japan Panasonic vacuum sensor, with automatic pneumatic stop function, sensitive reaction, stable performance
- Equipped with vacuum accumulator, long pressure protection time, safer to use
- Two pieces 12V20Ah high-capacity batteries, with sufficient power
- Not suitable for rainy day





10

Pneumatic Vacuum Lifter

Pneumatic suction caps are widely used in handling insulating glass, tempered glass, glass curtain wall, glass deep processing, solar photovoltaic glass, metal sheet, steel structure, MDF board, wooden panel and other industries. Time-saving, labor-saving and cost-saving, easy to use, no pollution; small and light in shape, single-person operation, non-destructive handling of workpieces, no external power supply; ergonomic design, sound and light alarm system, energy storage device, high safety, long service life and other characteristics; cooperate with the crane/jib crane to form a complete lifting and handling solution.

Operation Video on Youtube:
<https://youtube.com/shorts/xNcWrIn0fwA>



Pneumatic Glass Lifter

Model	GL-SC-150P	GL-SC-200P	GL-SC-300P	GL-SC-400P	GL-SC-500P
Lifting Capacity (kg)	150	200	300	400	500
Cup Qty	2	2	4	4	6
Cup Size mm	250	300	250	300	300
Raising Cylinder	SU100*1000	SU100*1000	SU100*1000	SU125*1000	160*1000
Rotating Cylinder	SU80*400	SU80*400	SU80*400	SU100*400	SU125*400
Tilting Cylinder	SU80*300	SU80*300	SU80*300	SU80*300	SU125*350
Max cups size mm	650	650	1150*780	1200*820	1200*820

Features & Advantages:

- -High stability and simple operation.
- -High efficiency and short handling cycle
- -High safety performance, equipped with air-cut protection and automatic braking device.
- -The main components are all internationally renowned brand products, and the quality is guaranteed.
- **Optional post (see picture)**



Pneumatic Metal Sheet Lifter

Model Type		GL-SC-100M1	GL-SC-200M1	GL-SC-300M1
Rated load capacity	kg	100	200	300
Suction cup size	mm	φ200	φ200	φ200
Number of suckers	pcs	4	6	6
Length of Main Beam	mm	1500	1500	1500
Length of Branch Beam	mm	600	600	600
Sheet metal Length	mm	2500	2500	2500
Packing Size	mm	1550*620*480	1550*620*480	1550*620*480
Weight	kg	80	90	100

Features & Advantages:

- -High stability and simple operation.
- -High efficiency and short handling cycle
- -High safety performance, equipped with air-cut protection and automatic braking device.
- -The main components are all internationally renowned brand products, and the quality is guaranteed.
- **Optional Post (see picture)**





11

Mini Hydraulic Floor Crane

The Mini Hydraulic Floor Crane is usually used in assembly workshop, machining workshop, assembly mold, research laboratory, maintenance workshop, small freight station, warehouse, repair shops etc. Especially in the narrow passage and limited space.

Operation Video on Youtube: <https://youtu.be/2snZrYJEwGc>



Specification Details

Model Type	EPFC-25	EPFC-25-AA	EPFC-CB-15	EPSC900R Electric rotation240°
Picture				
Horizontal Reach (Extended 2 stages)	1280+610+610mm	1280+610+610mm	1220+610+610mm	1280mm+610mm+610mm
Load Capacity	1200kg	1200kg(1280mm)	700kg(1220mm)	900kg(1280mm)
Load Capacity(stage 1)	600kg(1280~1890mm)	600kg(1280~1890mm)	400kg(1220~1830mm)	450kg(1280~1890mm)
Load Capacity(stage 2)	300kg(1890~2500mm)	300kg(1890~2500mm)	200kg(1890~2440mm)	250KG(1890~2500mm)
Max Lifting Height	3570mm	3540mm	3560mm	3180mm
MinLifting Height	960mm	935mm	950mm	1410mm
Retracted size(W*L*H)	1920*760*1600mm	1865*1490*1570mm	2595*760*1580mm	2000*1854*1550mm
Arm Electric Rotation	/	/	/	120° left/right

Features & Advantages:

- * Fully powered shop cranes (power hoist & power in/out boom) for moving loads quickly, easily, and safely.

- * 24V DC drive and lift motor handles heavy-duty jobs. Ergonomic handle features easy-to-operate throttle with infinite adjustment of forward and reverse speeds, lift/lower controls, proprietary safety-enhancing emergency reverse function, and horn.

- * Includes an electromagnetic disc brake with automatic dead-man feature that activates when user releases the handle.

- * Powered shop crane has two 12V, 80 - 95/Ah lead acid deep cycle batteries, integral battery charger, and battery level gauge.

- * Poly-on-steel steer and load wheels.





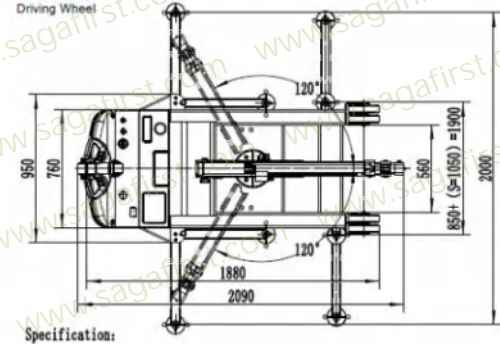
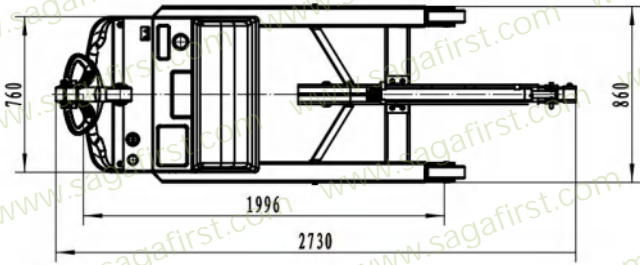
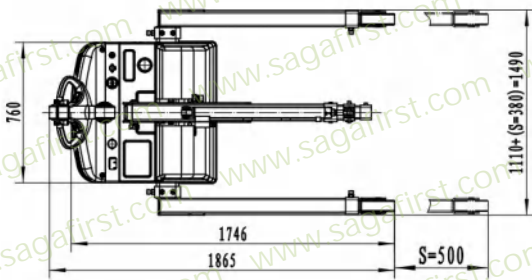
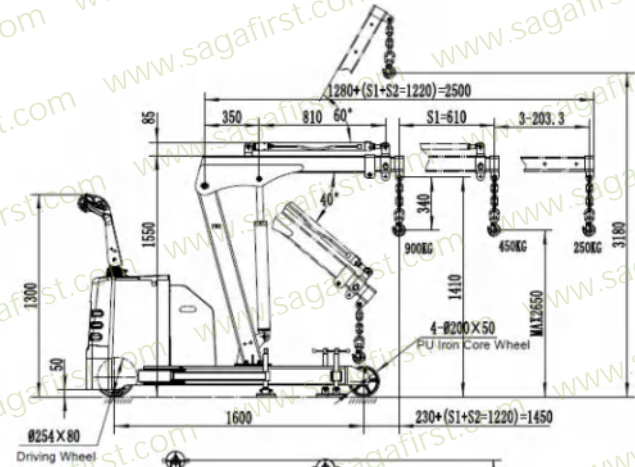
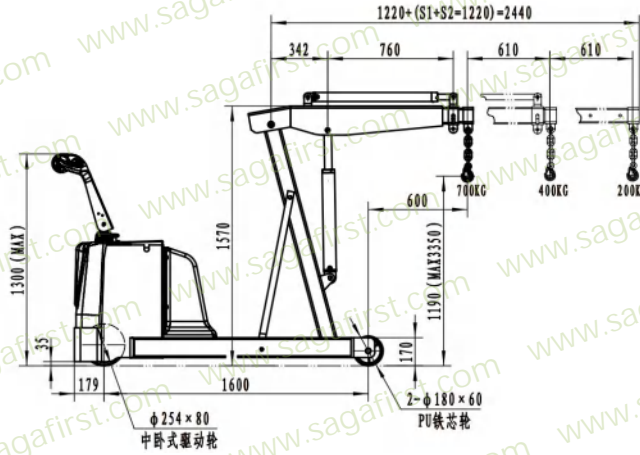
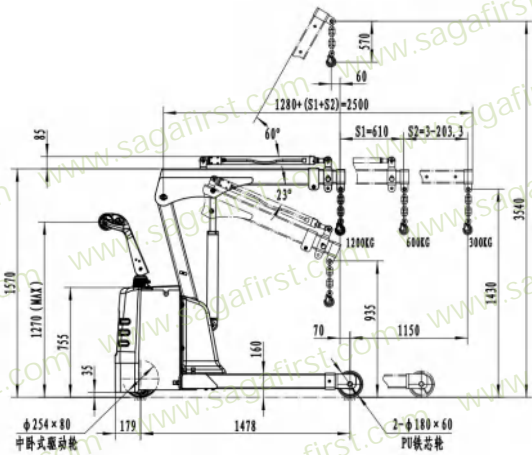







- * 3-4 hour operation at full charge - 8 hours when used intermittently. Includes rigid hook with safety latch

Technical Drawing (EFPC-25-AA, EFPC-CB-15, EPSC900R)



Specification:

Details

<p>Adjustable leg</p>	<p>Control panel</p>	<p>Cylinder</p>	<p>Power switch</p>
			
<p>Extended boom</p>	<p>Hook with chain</p>	<p>Main boom</p>	<p>Pu wheel</p>
			
<p>Move handle</p>	<p>Oil Valve</p>	<p>Option handle</p>	<p>Lifting ring</p>
			

12

Car Mover

The full electric car mover is specially designed for automobile manufacturers, parking lots, exhibition halls, residential quarters, underground parking lots, residential villas, corporate parking lots, commercial parking lots, and can realize no ignition shift steering. The electronic stepless speed regulation system has stable performance and simple operation. Equipped with power battery for longer, equipped with intelligent charger, no need for special monitoring during the entire charging process

Operation Video on Youtube: <https://youtu.be/wZaJV2Pi4Ug>



Specification Details

Model	ECM-2500	ECM-3500
Loading Capacity	2500KG	3500KG
Battery	2x12V/210AH	2x12V/210AH
Charger	24V/30A	24V/30A
Driving Motor	DC24V/1200W	DC24V/1500W
Lifting Motor	24V/2000W	24V/2000W
Climbing Capacity(unloaded)	10%	10%
Climbing Capacity(loaded)	5%	5%
Materials	Steel panel 6mm	
Battery Power Indicator	Yes	
Driving Wheel	PU	
Driving speed	0~6.5Km/h E-CVT	
Lifting height	115mm	
Braking type	Electromagnetic braking	
Street Request	2000mm can move Forward and Backward	
Packing Size	2 wooden carton: 2.3*2*0.3m,and 1*0.8*1.45m	
Weight	800/900kg	

Features & Advantages:

- * Simple operation, safe and reliable, ultra low noise
- * Transporting your vehicle safely to its intended places.
- * Adopt super good steel materials, not easy to cause deformation, beautiful, security and practical.
- * Heavy duty design with different load: 1500kg, 2500kg, 3500kg and 4500kg to move different vehicles
- * Maintenance free battery, equipped with high efficient charger
- * Durable driving motor and powerful lifting motor
- * Meet international standard climbing ability : 10% unloaded and 5% loaded

Technical Drawing (ECM-2500, ECM-3500)

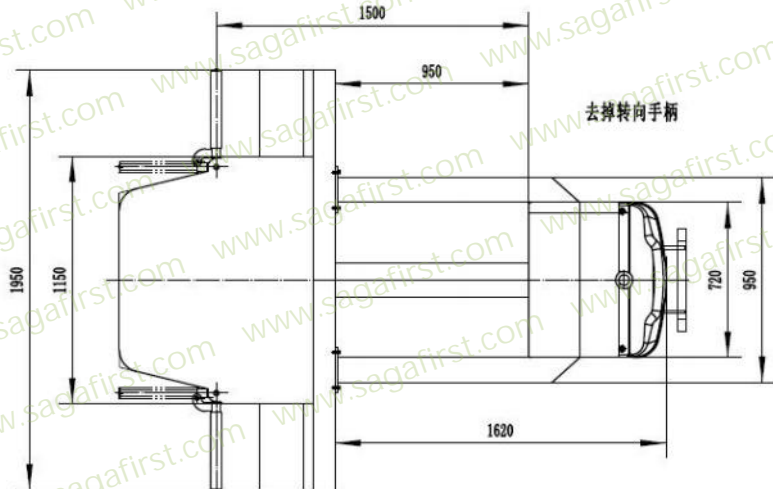
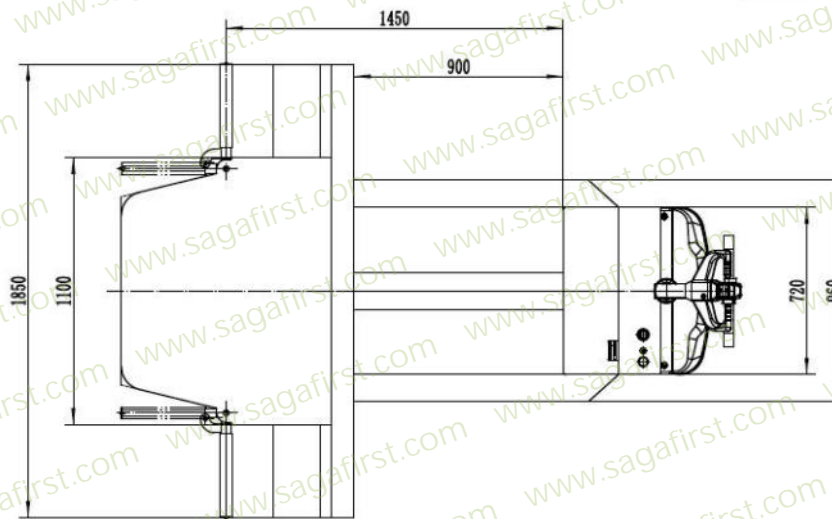
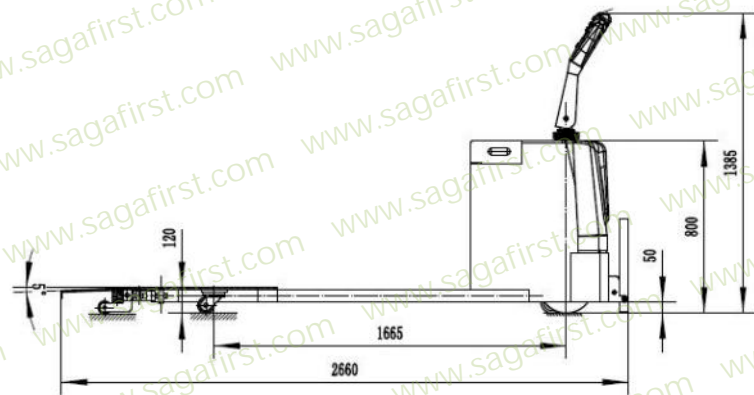
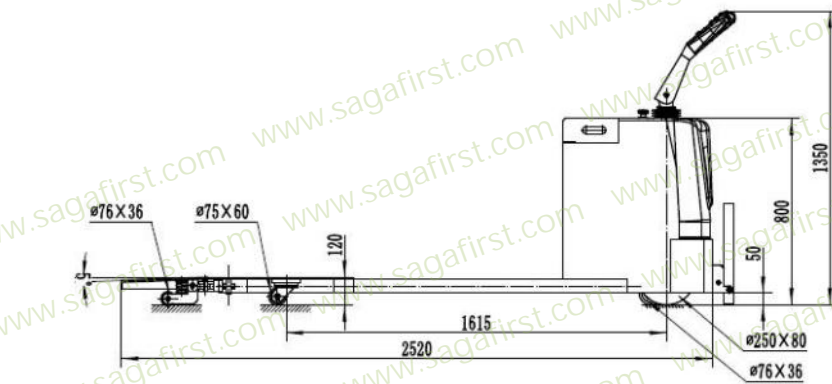

13

Car Turn Table

Sagafirst Car Rotary Stage adopts much stronger materials and parts to increase the load capacity and lifting height. We will make the platform size, lifting height and load capacity as per your requests.

Operation Video on Youtube: https://youtu.be/cLbBRzAj_jc

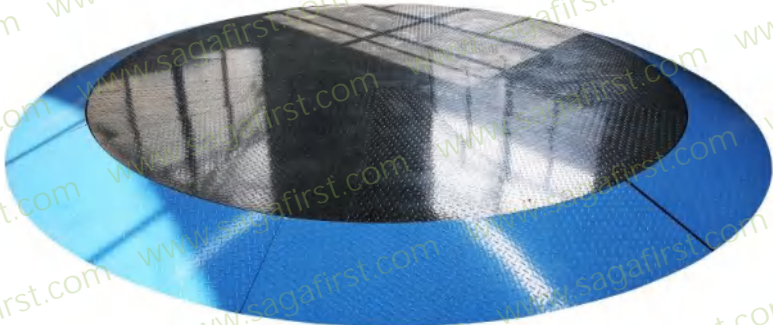

Specification Details

Model No.	CRS3-3.0	CRS3-4.0	CRS3-4.5	CRS3-5.0	CRS3-5.5	CRS3-6.0
Type	Gear Transmission/Friction Transmission					
Operation	Remote Control Frequency Conversion					
Diameter(mm)	3000	4000	4500	5000mm	5500	6000
Load Capacity(Kg)	3000					
Self Height	320/135					
Rotatory Speed (mm/s)	400/300					
Platform Material	4mm Checkered Steel Plate/5mm Checkered Aluminum Plate(Optional)					
Power Supply Parameter	Customized					
Motor Power(W)	750*1/120*4					
Sectorial Frame	40*40 Rectangular Tube+60*60 Square Tube					
Package Size	2.2*1.8*0.55	2.2*2*0.7	2.2*2*0.85	2.6*2.25*0.86	2.75*2.2*0.85	3.03*2.2*1
Weight	1050	1450	1800	2250	2750	3000



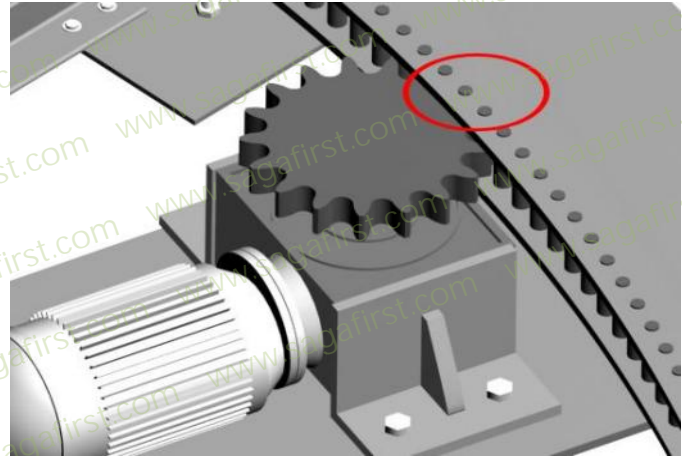
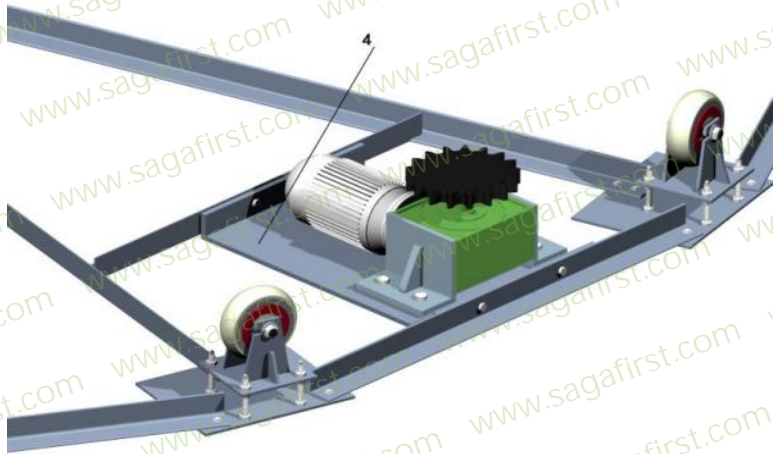
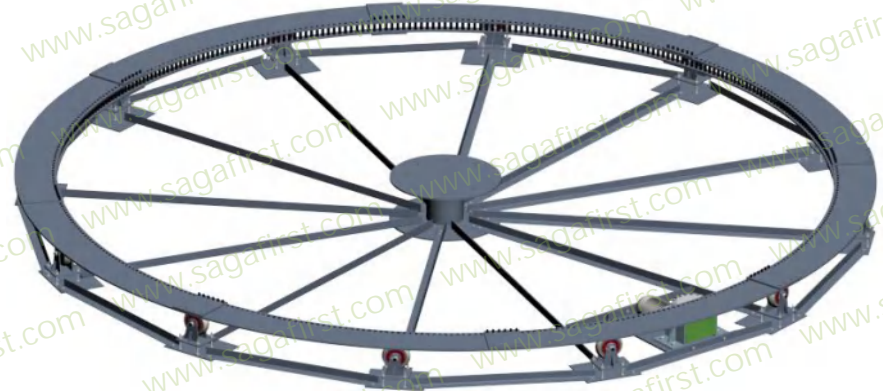
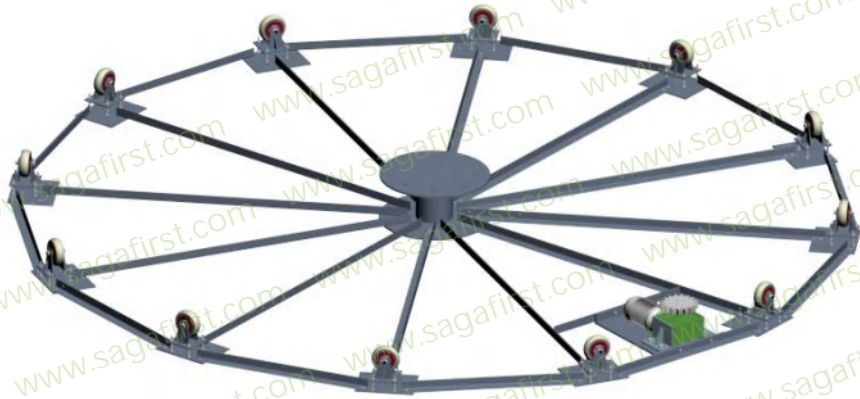



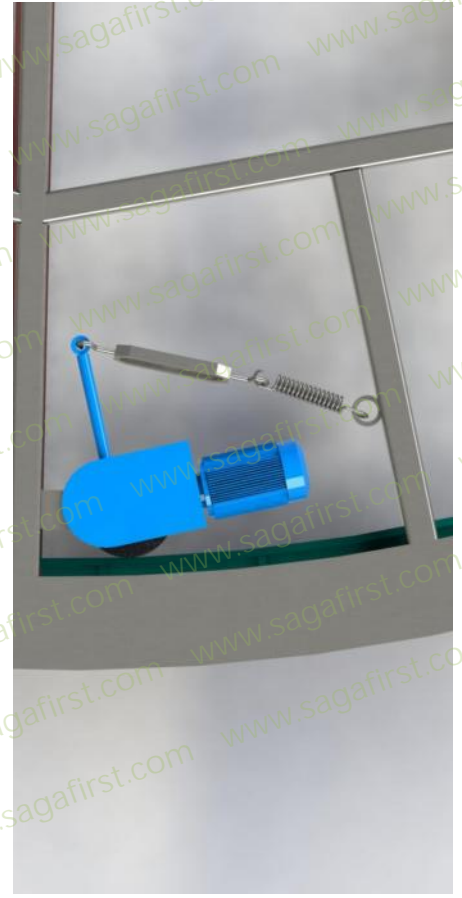

3D Gear Transmission Schematic Drawing



3D Friction Transmission Schematic Drawing



Details

Remote Control	Electric Box	Frequency Converter	Sectorial Frame
			
Gear Transmission	Friction Transmission	Support Legs	Aluminum Checkered Plate
			

QINGDAO SINOFIRST MACHINERY CO.,LTD

Qingdao Sinofirst Machinery Co.,Ltd is a professional manufacturer and exporter for Aerial Platform,Lifting Equipment and Material Handling Equipment.

The company are inspected and approved by SGS, BV and TUV. Main products includes hydraulic scissor lift,aluminum lift,boom lift,lift table,turn table,cargo lift,wheelchair lift,vacuum lifter,electric crane,car mover,electric tractor and so on,approved by CE ROHS and meet international standards, widely export to Europe, North America,Asia and South America countries.

Our professional sales team and technical team can give fast solution and strong support as per demands.SINOFIRST aims to "provide customer the most reliable machine".SINOFIRST factory covers more than 300 acres and a building area of up to 10,000 square meters.With high new technologies, the Company are rich of production experience,using advanced processing equipment such as Germany automatic bending robot and laser cutting machine imported,Japan Hamada NC punch press,large automated surface coating production line and general assembly production line.

In 2005,SINOFIRST introduce more automatic production line like automatic painting line,welding line and assemble line,greatly improved the production efficiency and precision.Each year, SINOFIRST invest more than 10 million to develop new technology and products for the realization of light structure design, integrated control system, refined hydraulic system, scientific combination and matching.

We have created a batch of safe, reliable, high-efficiency and environmental-friendly hydraulic machinery and vacuum machinery.SINOFIRST will always keep "Development Spirit,Customer First".

Welcome dealers,trading companies and end users to visit us and negotiate business.Please don't hesitate to contact us online or by email.



Qingdao Sinofirst Machinery Co.,Ltd

THANK YOU!

Welcome to Contact Us

Qingdao Sinofirst Machinery Co., Ltd

Add: Danshan Industrial Park,Chengyang,Qingdao,China

Tel:+86-532-68076300 Mob:+86-13668863425

Whatsapp/Wechat:+86-13668863425

Email:alison@liftawp.com



Whats-App



We-Chat



www.saga-boom.com



www.sagafirst.com



www.liftawp.com

